

CAST STEEL BALL VALVES – ANSI CLASS 300

DESIGN DESCRIPTION:

- FULL PORT
- FIRE SAFE CONSTRUCTION
- TWO PIECE BODY
- FLOATING BALL TYPE
- ANTI-STATIC DEVICE
- BLOW OUT PROOF STEM
- STOPPER DEVICE
- ISO 5211 MOUNTING PAD
- FLANGE ENDS
- BUTTWELDING ENDS

APPLICABLE STANDARDS:

- METAL BALL VALVES, API 608
- FIRE SAFE, API 607
- STEEL VALVES, ANSI B16.34
- FACE TO FACE, ANSI B16.10
- END FLANGES, ANSI B16.5
- BUTTWELDING ENDS, ANSI B16.25
- INSPECTION AND TEST, API 598

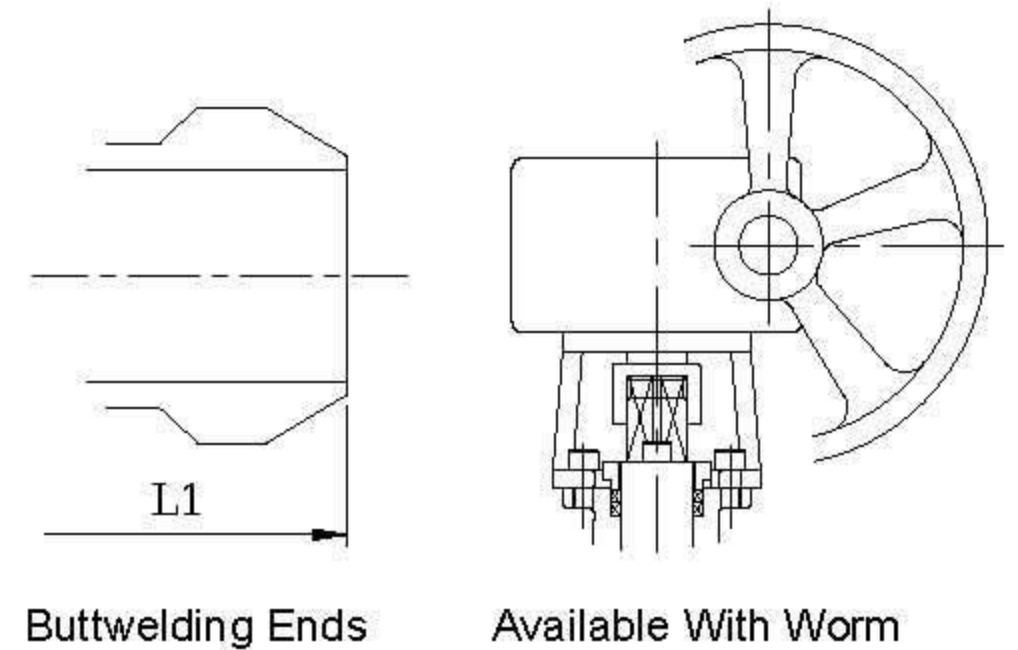
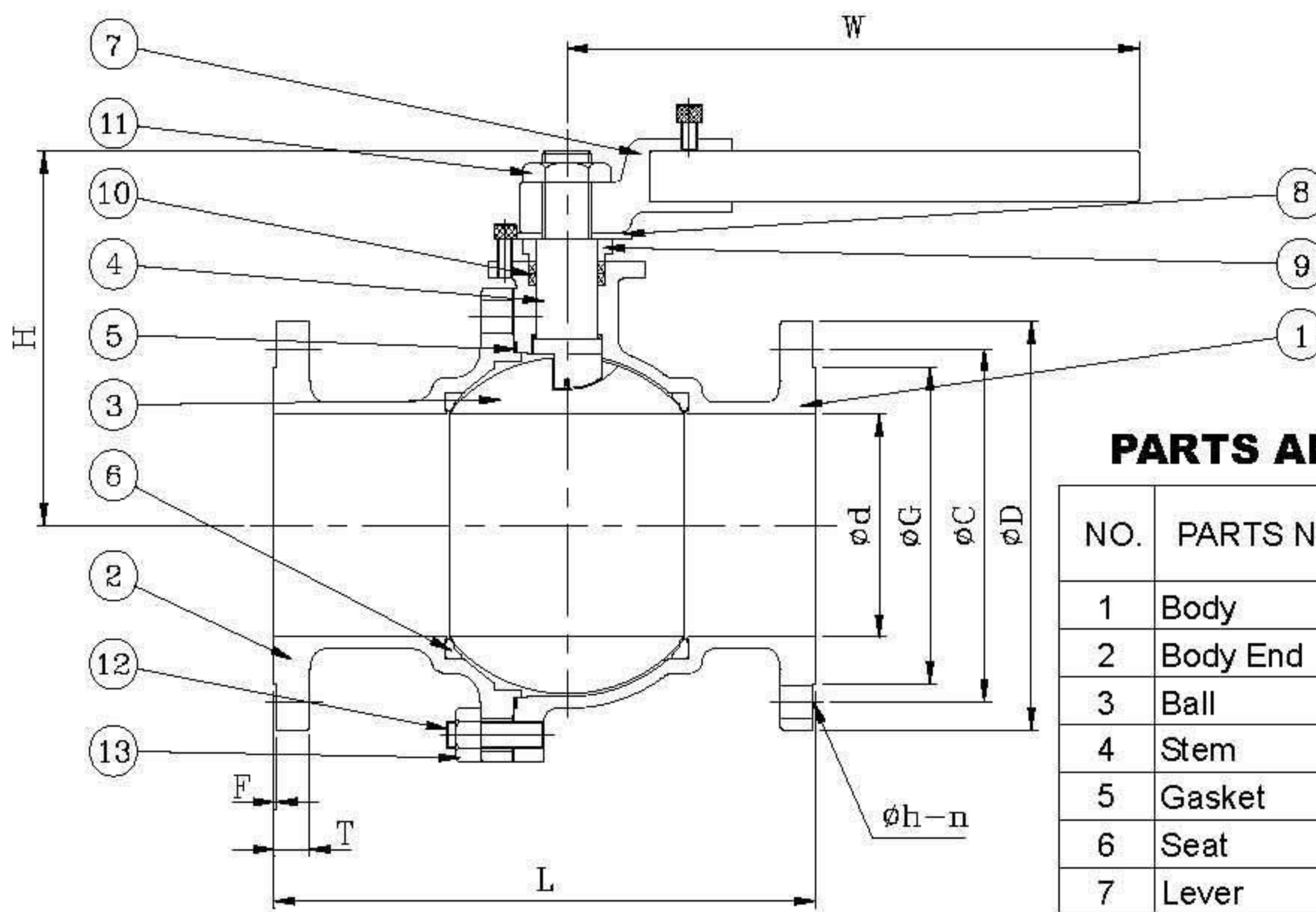

PARTS AND MATERIAL (ASTM)

NO.	PARTS NAME	MATERIALS		
		WCB	CF8	CF8M
1	Body	A216-WCB	A351-CF8	A351-CF8M
2	Body End	A216-WCB	A351-CF8	A351-CF8M
3	Ball	A351-CF8	A351-CF8	A351-CF8M
4	Stem	A276-304	A276-304	A276-316
5	Gasket	Grafoil+316 sheet		
6	Seat	RTFE		
7	Lever	A536		
8	Stopper	A240-304		
9	Gland Flange	A351-CF8		
10	Gland Packing	Grafoil		
11	Lever Nut	B16 / AISI 304		
12	Body Bolt	A193-B7	A193-B8	A193-B8
13	Nut	A194-2H	A194-8	A194-8

OTHER MATERIALS ARE AVAILABLE UPON REQUEST.

TEST PRESSURE TO API 598

PSIG

SHELL TEST (water)	SEAT TEST (water)	SEAT TEST (air)
1125 (79 kg/cm ²)	—	80 (6 kg/cm ²)

DIMENSION TABLE:

DN	NPS	Ø d	L	L1	H	W	T	F	Ø D	Ø C	Ø G	Ø h	n
15	1/2	12.7	140	140	54	150	14.3	1.6	95.3	66.5	35.1	16.0	4
20	3/4	19.0	152	152	60	150	15.8	1.6	117.4	82.6	43.0	19.0	4
25	1	25.4	165	165	68	150	17.5	1.6	124.0	88.9	50.8	19.0	4
40	1 1/2	38.1	191	191	85	232	20.6	1.6	155.5	114.3	73.2	22.3	4
50	2	50.8	216	216	110	232	22.4	1.6	165.1	127.0	92.0	19.0	8
65	2 1/2	63.5	241	241	146	350	25.4	1.6	190.5	149.4	104.7	22.3	8
80	3	76.2	282	282	156	350	28.5	1.6	209.6	168.1	127.0	22.3	8
100	4	101.6	305	305	192	400	31.8	1.6	254.0	200.2	157.2	22.3	8
150	6	152.4	403	457	260	800	36.6	1.6	317.5	269.8	215.9	22.3	12
200	8	203.2	502	521	317	1100	41.2	1.6	381.0	330.2	269.8	25.4	12
250	10	254.0	568	559	364	1200	47.8	1.6	444.5	387.4	323.9	28.5	16
300	12	304.8	648	635	G/0	G/0	50.8	1.6	520.7	450.9	381.0	31.8	16